

Paramount

Item #PH-F122
Model # KLD7003S/
KLD7003SS

USE AND CARE GUIDE

OUTDOOR SPIRAL FLAME HEATER

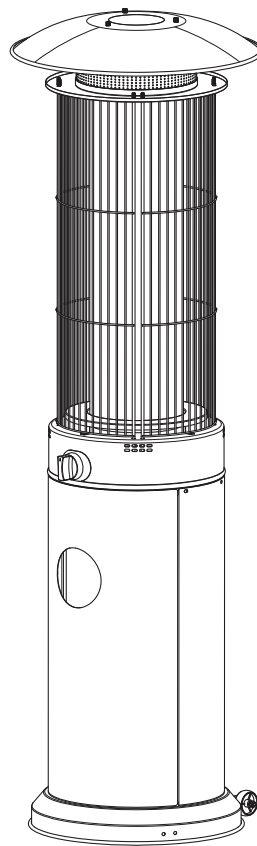

**ELECTRONIC IGNITION
REQUIRES 1 AA BATTERY
(NOT INCLUDED)**



DANGER: Carbon Monoxide Hazard. This appliance can produce carbon monoxide, which has no odour. Using it in an enclosed space can kill you. Never use this appliance in an enclosed space such as a camper, tent or home.



DANGER: If you smell gas

- Shut off gas to the appliance
- Extinguish any open flame
- If odour persists, keep away from the appliance and call your gas supplier or fire department.



WARNING: For outdoor use only.

Questions, problems, missing parts? Before returning to the store, please contact customer service at customercare@jrhome.com or call 1-800-561-5550 7 a.m. - 4 p.m., PST, Monday – Friday

1-800-561-5550

WWW.PARAMOUNTATHOME.COM



THANK YOU

We appreciate the trust and confidence you have placed in Paramount through the purchase of this Outdoor Heater. We strive to continually create quality products designed to enhance your home. Visit us online to see our full line of products available for your home improvement needs. Thank you for choosing Paramount!

Table of Contents

Table of Contents	2
Safety Information	2
Warranty	
What is covered	3
What is not covered	3
Pre-Installation	2-3
Planning Installation	2
Hardware Included	2
Package Contents	3

Assembly	6-10
Operation	
Pre-operation	11
Leak Test	11
Lighting the heater	12
Turning off the heater	12
Relighting	12
Operational checklist	13
Post-Operation	13
Maintenance, Care & Cleaning	14
Troubleshooting	15

Safety Information

1. This appliance has been tested to and complies with the ANSI STD Z83.26-2020/CSA 2.37-2020, Gas-Fired Outdoor Infrared Patio Heaters. The installation must conform to local codes or in the absence of local codes to the National Fuel Gas Code. ANS Z223.1. We cannot foresee every use which may be made of our appliance. Check with your local fire safety authority if you have questions about your appliance use. Other standards govern the use of fuel gases and heat producing products for specific uses. Your local authorities can advise you about these.
2. This manual contains important information about the assembly, operation and, maintenance of this appliance. General safety information is presented in these first few pages and is also located throughout. Keep this manual for future reference and to educate new users of this product. This manual should be read in conjunction with the labeling on the product.
3. Safety precautions are essential when any mechanical or gas fueled equipment is involved. These precautions are necessary when using, storing, and servicing. Using the equipment with the respect and caution demanded will reduce the possibilities of personal injury or property damage. Always heed these precautions, as they are essential when using any mechanical or gas fueled equipment. Failure to comply with the precautions and instructions provided with this appliance can result in death, serious bodily injury and property loss or damage from hazards of fire, explosion, burn, asphyxiation, and of carbon monoxide poisoning. Only persons who can understand and follow the instructions should use or service this appliance.
4. Keep solid combustibles such as building materials, paper, or cardboard a safe distance away from the appliance as recommended by the instructions.
5. Provide adequate clearances around air openings into the combustion chamber.
6. Never use the appliance in spaces which do or may contain volatile or airborne combustibles, or products such as gasoline, solvents, paint thinner, dust particles, or unknown chemicals. During operation, this appliance can be a source of ignition. Keep appliance area clear and free from combustible materials, gasoline, paint thinner, cleaning solvents and other flammable vapors and liquids. Do not use the appliance in areas with high dust content.
7. Minimum appliance clearances from combustible materials: 2 feet (24 inches/61cm) from the sides & 2 feet (24 inches/61cm) from the rear, 3 feet (36 inches/91.5cm) from ceiling.
8. Never install or remove a propane cylinder while the appliance is lighted, near flame, pilot lights, or other ignition sources or while the appliance is hot to the touch. This appliance is red hot during use and can ignite flammables too close to the burner. Keep flammables at least 3 feet (36 inches/91.5cm) from top and 2 feet (24 inches/61cm) from sides. Keep gasoline and other flammable liquids and vapors well away from the appliance.
9. Store the propane cylinder outdoors in a well ventilated space out of the reach of children. Never store the propane cylinder in an enclosed area (house, garage, etc.). If the appliance is to be stored indoors disconnect the propane cylinder for outdoor storage.
10. Never store propane near high heat, open flames, pilot lights, direct sunlight, other ignition sources or where temperatures exceed 120 degrees F (49 degrees C)

 **WARNING:** Do not store or use gasoline or other flammable vapors and liquids in the vicinity of this or any other appliance.

Any LP-cylinder not connected for use shall not be stored in the vicinity of this or any other appliance.

 **WARNING:** Improper installation, adjustment, alteration, service or maintenance can cause property damage, injury or death. Read the installation, operation and maintenance instructions thoroughly before installing or servicing this equipment.

 **WARNING:** This product can expose you to chemicals, including carbon monoxide, which is known to the State of California to cause birth defects or other reproductive harm. For more information go to www.P65Warnings.ca.gov.

Pre-Installation-Tools and Hardware

PLANNING INSTALLATION

Before beginning assembly, be sure to empty contents of carton and make sure all parts are present. Place all parts on a soft, level surface for assembly. If any parts are missing, please contact Customer Service between 8 a.m. - 7 p.m., EST, Monday – Friday, 9 a.m. – 6 p.m., EST, Saturday.

Estimated Assembly Time: 30 minutes



NOTE: You will need a leak test solution. See page 11 for instructions.

HARDWARE INCLUDED



WARNING: Keep children away during assembly. This item contains small parts which can be swallowed by children.



NOTE: Hardware not shown to actual size.

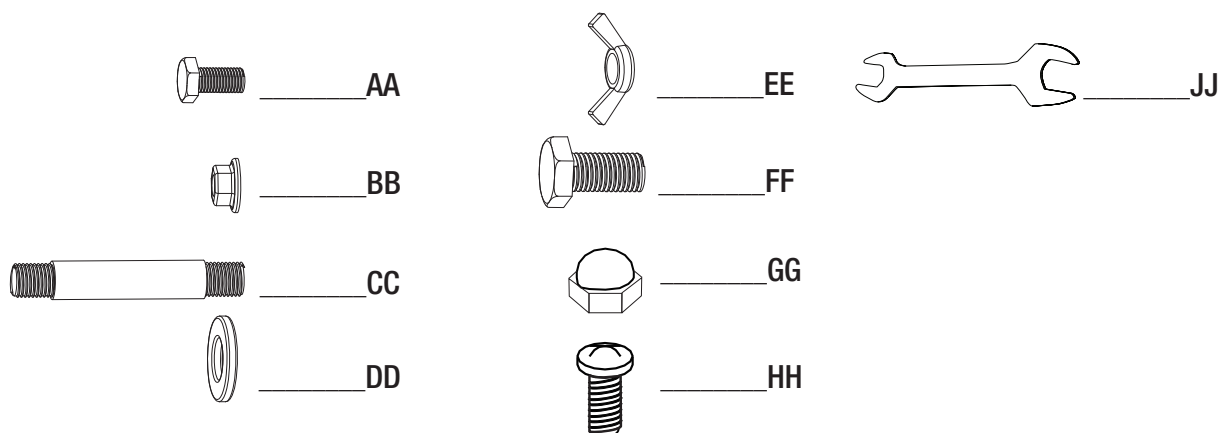

Part	Description	Quantity
AA	M6 x 12mm Bolt	6
BB	M6 Nut	22
CC	M8 Bolt	3
DD	M8 Washer	6
EE	Wing Nut	3
FF	M8 x 16mm Bolt	2
GG	Cap Nut	8
HH	M5x8mm Screw	8
JJ	Wrench	1

Pre-Installation-Package Contents

PACKAGE CONTENTS

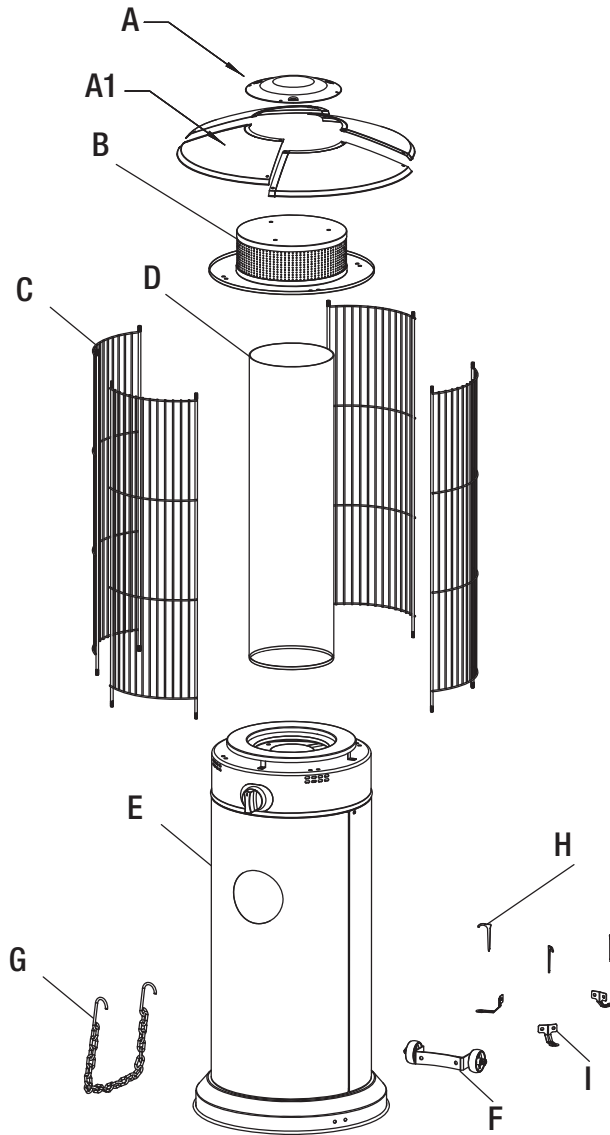

Part	Description	Quantity
A	Reflector Center Cap	1
A-1	Reflector Panel	4
B	Emitter Screen	1
C	Protection Guard	4
D	Glass Tube with Gasket	1
E	Tank Assembly	1
F	Wheels	1
G	Chain	1
H	Anchoring Pins	3
I	Anchoring Arms	3

Assembly

1 Attaching The Wheels To The Tank Assembly



NOTE: If permanently anchoring the heater to the ground or patio, skip to step 2.

- Line up holes in the wheels (F) with the corresponding holes in the base of the tank assembly (E) and insert two M8x16 screws (FF) through the holes. Finger tighten the bolts.
- Make sure the wheels (F) are parallel to the base of the tank assembly (E) and then fully tighten the bolts using the wrench (JJ).

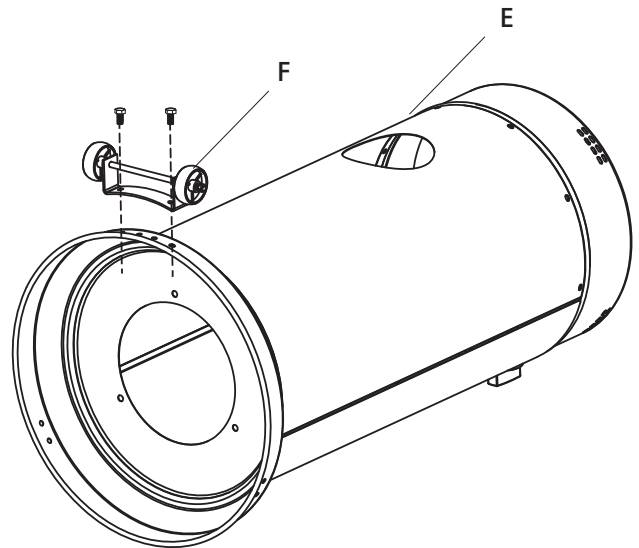

2 Attaching The Anchoring Arms

- Attach one anchoring arm (I) to the base of the tank assembly (E) with two M6x12 screws (AA) and two M6 nuts (BB) as shown. Repeat for the other 2 anchoring arms (I) so all 3 are attached to the base of the tank assembly (E).
- Once the heater is completely assembled, if you wish to anchor the heater to the ground, insert the anchoring pins (H) through the anchoring arms (I) and directly into the ground as shown.



NOTE: Only 2 anchoring arms can be used in conjunction with wheel assembly.

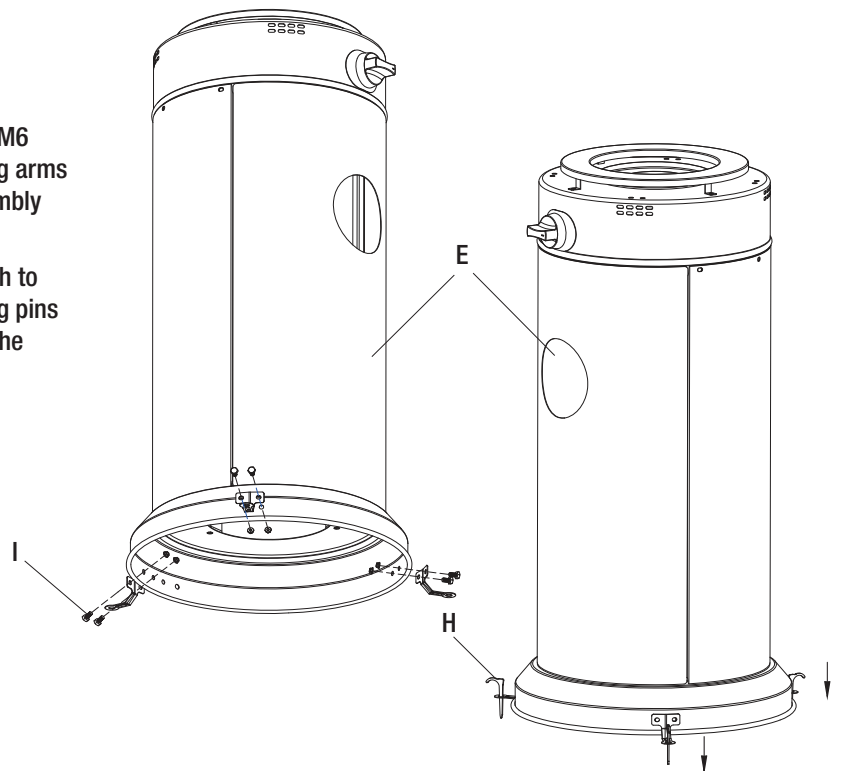

Assembly - (continued)

3 Attaching The Protection Guard

- Attach the protection guards (C), longer ends down, to the holes on the top of the tank assembly (E).
- Use eight M6 nuts (BB) to tighten the protection guards (C).

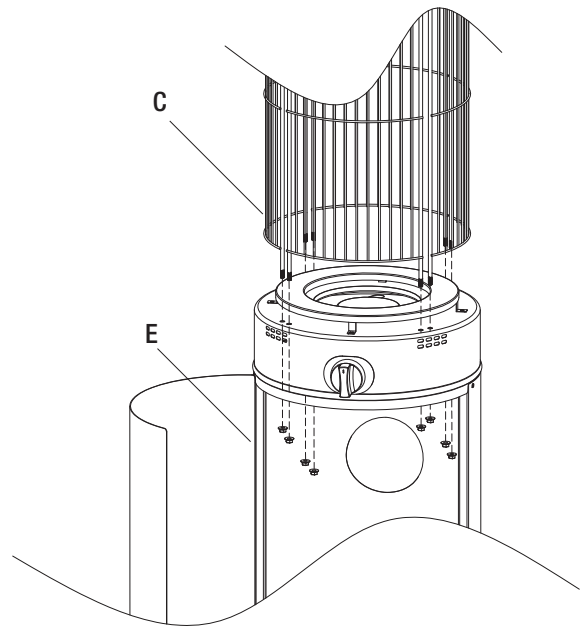

4 Reflector Assembly

NOTE: MAKE SURE TO REMOVE PROTECTIVE PLASTIC COVER ON REFLECTOR PIECES PRIOR TO ASSEMBLY



NOTE: If necessary for proper alignment of reflector sections, loosen each screw prior to further assembly and retighten after sections are aligned.

- Slide two Reflector Panels (A-1) together. Insert one Screw (LL). Screw on Cap Nut (KK) loosely.
- Repeat with other Reflector Panels (A-1).
- Slide Reflector Center Cap (A) onto assembled Reflector Panels (A-1).
- Insert one Screw (LL) and screw on Cap Nut (KK) loosely. Repeat with three more to complete reflector assembly. Fully tighten all screws and cap nuts.

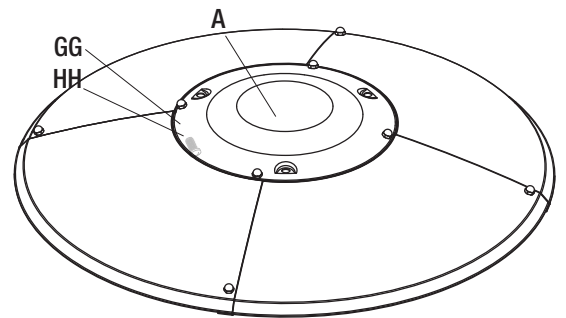
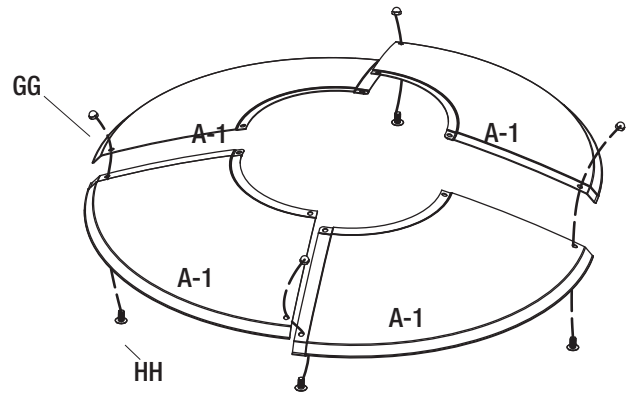

Assembly (continued)

5 Attaching The Reflector

- Insert three M8 bolts (CC) into the holes on the emitter screen (B). Tighten the bolts securely.
- Attach three M8 washers (DD) over the bolts (CC), place the reflector (A) onto the bolts and attach three M8 washers (DD) over the bolts (CC) and onto the reflector (A). Secure with three wing nuts (EE). *Do not over tighten.*

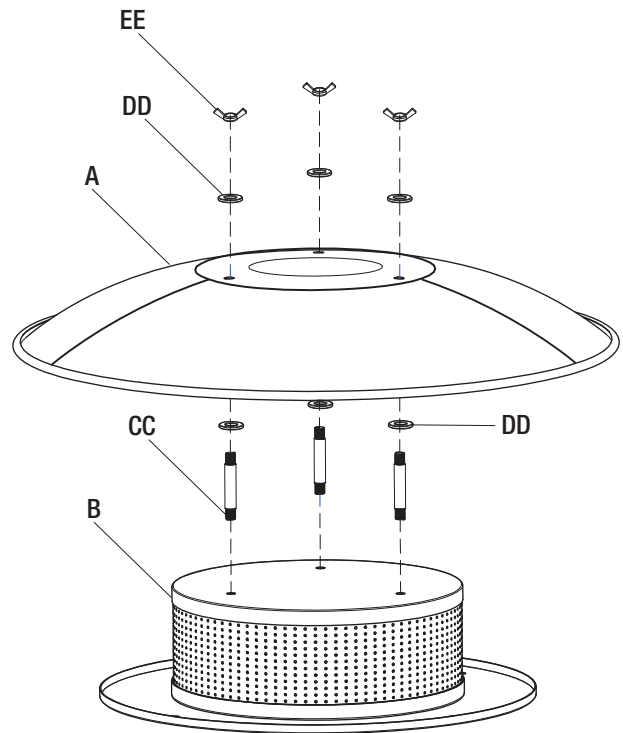

6 Placing The Glass Tube

- Place the glass tube (D) onto the tank assembly (E).
Note: Make sure the white gasket is in place at the bottom of the glass tube.

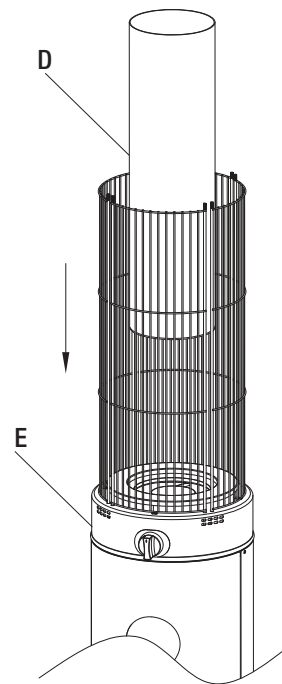

Assembly (continued)

7 Placing The Emitter Screen

- Place the emitter screen assembly (B) onto the protection guards. Make sure the thread goes through the holes on the bottom of the emitter screen assembly.

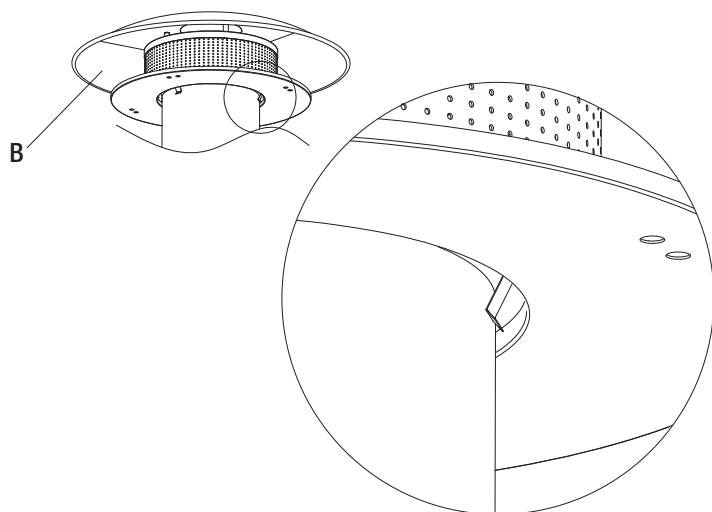

8 Tightening The Guards

- Use eight M6 nuts (BB) to tighten the protection guards (C).

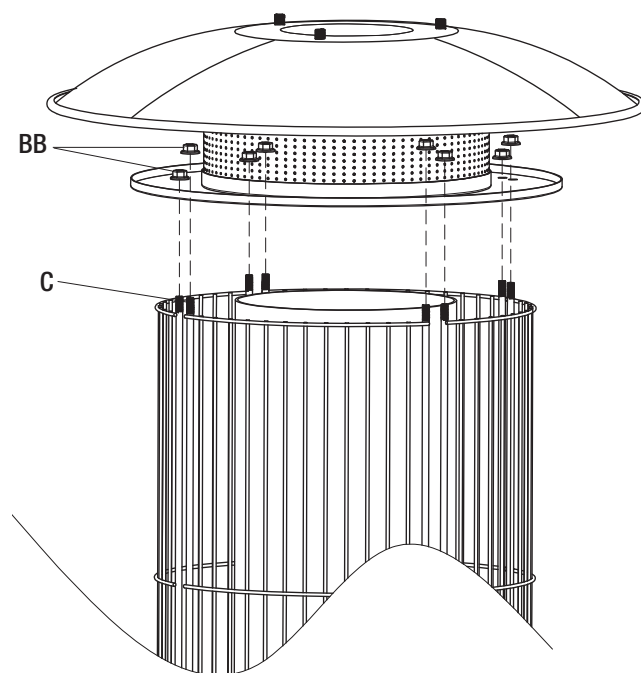

Assembly (continued)

9 Adding the Chain

- Hook the chain (G) into the holes of the tank housing.

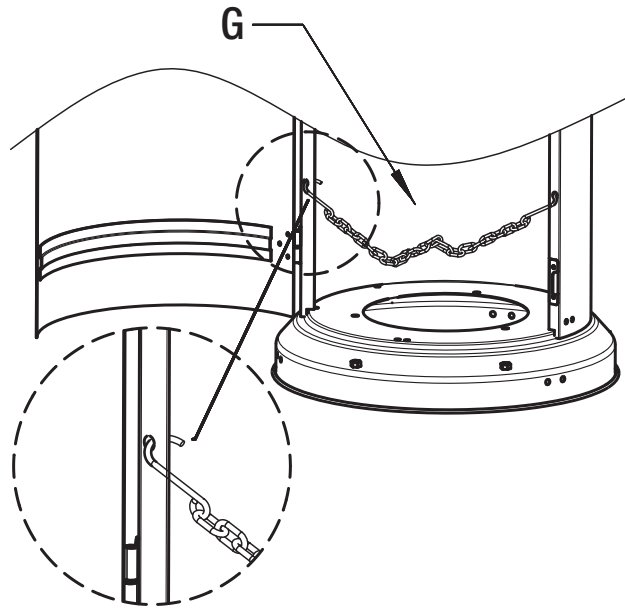

10 Connecting The Propane Tank

- Connect the hose and regulator to a standard 20lb propane gas cylinder (sold separately). Use a standard 20lb propane cylinder only. Use this appliance only with a propane vapor withdrawal supply system. See chapter 5 of the standard storage and handling of liquefied petroleum gas, ANS/NFPA 58. Your local library or fire department should have this book.
- Storage of an appliance indoors is permissible only if the cylinder is disconnected and removed from the appliance. A cylinder must be stored outdoors in a well-ventilated area out of the reach of children. A disconnected cylinder must have dust caps tightly installed and must not be stored in a building, garage or any other enclosed area. The maximum inlet gas supply pressure: 250 psi, the minimum inlet gas supply pressure: 5 psi.
- The minimum hourly of 10,000 BTU is required input rating for a appliance for automatic operation at ratings less than full input rating. The pressure regulator and hose assembly supplied with the appliance must be used.
- The installation must conform with local codes, or in the absence of local codes, with national fuel gas code, ANS Z223.1/NFPA54, natural gas and propane Installation Code, CSA B 149.1, or propane storage and handling code, B149.2.

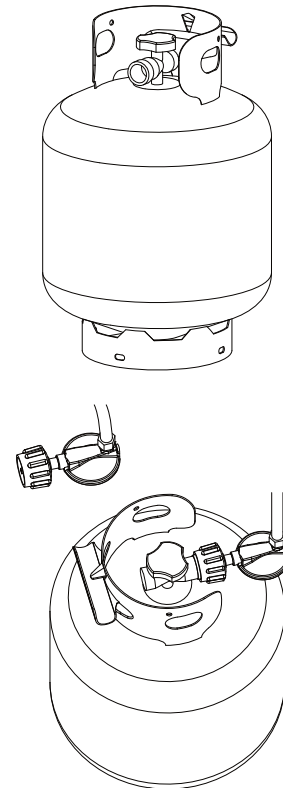

Operation

1 Pre-Operation



CAUTION: Do not attempt to operate this appliance until you have read and understand all Safety Information in this manual and all assembly is complete and leak tests have been performed.

- ❑ A dented, rusted or damaged propane cylinder may be hazardous and should be checked by your cylinder supplier. Never use a propane cylinder with a damaged valve connection.
- ❑ The propane cylinder must be constructed and marked in accordance with the specifications for LP gas cylinders of the US Department of Transportation (DOT) or the standard for cylinders, spheres and tubs for transportation of dangerous goods and commission, CAN/CSA-B339.
- ❑ The cylinder used must include a collar to protect the cylinder valve.
- ❑ The cylinder must have a listed overfilling prevention device.
- ❑ Do not store a spare LP gas cylinder under or near this appliance;
- ❑ Never fill a cylinder beyond 80% full.
- ❑ Place the dust cap on the cylinder valve outlet whenever the cylinder is not in use. Only install the type of dust cap on the cylinder valve that is provided with the cylinder valve. Other type of caps or plugs may result in leakage of propane
- ❑ Do not use indoors or inside any enclosure.
- ❑ Retain the assembly instructions for future reference.
- ❑ Installer — please leave these instructions with the owner.

Before Turning Gas Supply ON:

1. Your heater was designed and approved for OUTDOOR use only. Do NOT use it inside a building, garage, or any other enclosed area.
2. Make sure surrounding areas are free of combustible materials, gasoline, and other flammable vapors or liquids.
3. Ensure that there is no obstruction to air ventilation. Be sure all gas connections are tight and there are no leaks.
4. Be sure the cylinder cover is clear of debris. Be sure any component removed during assembly or servicing is replaced and fastened prior to starting.

Before Lighting:

1. Heater should be thoroughly inspected before each use, and by a qualified service person at least annually. If re-lighting a hot heater, always wait at least 5 minutes.
2. Inspect the hose assembly for evidence of excessive abrasion, cuts, or wear. Suspected areas should be leak tested. A leaky must be replaced prior to operation. Only use the replacement hose assembly specified by the manufacturer.

2 Performing A Leak Test



WARNING:

- ❑ Perform all leak tests outdoors.
- ❑ NEVER leak test when smoking.
- ❑ Extinguish all open flames. Never leak test with a match.
- ❑ Do not use the appliance until all connections have been leak tested and do not leak]

Make 2-3 oz. of leak test solution (one part liquid dishwashing detergent and three parts water).

1. Apply several drops of solution where hose attaches to regulator.
2. Apply several drops of solution where regulator connects to cylinder.
3. Make sure all valves are turned OFF.
4. Turn cylinder valve ON.

If bubbles appear at any connection there is a leak.

1. Turn cylinder valve OFF.
2. If leak is at hose/regulator connection: tighten connection and perform another leak test. If bubbles continue appearing, the hose should be returned to the place of purchase or email customercare@jrhome.com for assistance.
3. If leak is at regulatory/cylinder valve connection: disconnect, reconnect, and perform another leak test. If you continue to see bubbles after several attempts, cylinder valve is defective and should be returned to cylinder's place of purchase.

If NO bubbles appear at any connection, the connections are secure.



NOTE: Whenever gas connections are loosened or removed, you must perform a complete leak test.

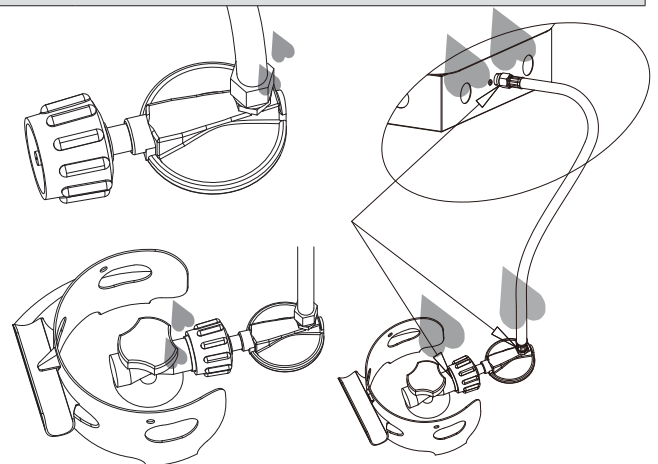

Operation - (continued)

3 Lighting The Heater



DANGER: Carbon Monoxide Hazard. This appliance can produce carbon monoxide, which has no odour. Using it in an enclosed space can kill you. Never use this appliance in an enclosed space such as a camper, tent or home.



WARNING: If at any time you are unable to light the burner and smell gas, wait 5 minutes to allow gas to dissipate before attempting to light heater. If after 1 minute, you are unable to light burner, wait 5 minutes and allow flammable vapors to dissipate before attempting to light heater again.



WARNING: Avoid inhaling fumes emitted from the heaters first use. Smoke and odor from the burning of oils used in the manufacturing will appear. Both smoke and odor will dissipate after approximately 30 minutes. The heater should NOT produce thick black smoke.



WARNING: Be careful when attempting to manually ignite this heater. Holding in the control knob for more than 10 seconds before igniting the gas will cause a ball of flame upon ignition.

Check and ensure that an AA battery (not included) is inside the ignition chamber and has power. Ensure the anode (+) faces outside.

1. Turn the control knob to the "OFF" position. Slowly open the gas cylinder valve.
2. Press and turn the control knob to Pilot position, push the igniter to generate a spark while keeping the control knob in the pressed position. Allow 30 seconds between ignition attempts for gas to dissipate. Several attempts may be necessary.
3. If the pilot lights, keep the control knob pressed for 15 seconds then turn the control knob to LO position then turn to HIGH.
4. If the burner fails to remain lit, close all valves and wait at least 5 minutes before attempting to light again.

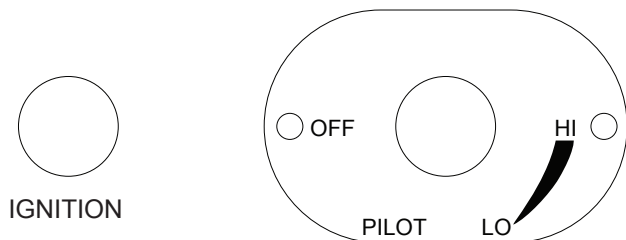

When the Heater is ON, the emitter screen will become bright red due to intense heat. The color is more visible at night. The burner will display tongues of blue and yellow flame. These flames should not be yellow or produce thick black smoke, indicating an obstruction of airflow through the burners. The flame should be blue with straight yellow tops. If excessive yellow flame is detected, turn off heater and consult "Troubleshooting" on page 15. If you experience any ignition problems, please consult "Troubleshooting" on page 15.



NOTE: After use, some discoloration of the emitter screen is normal.

4 Turning Off The Heater

1. Press and turn the control knob clockwise to the "OFF" position.
2. Turn the gas cylinder valve to OFF or closed and disconnect the cylinder



DANGER: If you smell gas

- Turn off the gas supply at the tank
- Extinguish all naked flames
- Do not operate any electrical appliances
- Ventilate the area.
- Check for leaks as detailed in this manual.
- If odour persists, contact your dealer or gas supplier immediately.

5 Re-Lighting The Heater



WARNING: FOR YOUR SAFETY: Heater will be hot after use. Handle with extreme care.

For your safety, the control knob can not be turned OFF without first depressing the control knob and then rotating to OFF.

1. Turn the control knob to the "OFF" position.
2. Wait at least 5 minutes to allow gas to dissipate before re-lighting.

Repeat the "Lighting The Heater" steps as listed.

6 Operational Checklist

For a safe and pleasurable heating experience, perform this check before each use:

1. I am familiar with entire owner's manual and understand all precautions noted.
2. All components are properly assembled, intact and operable.
3. No alterations have been made.
4. All gas connections are secure and do not leak.
5. Wind velocity is below 10 mph.
6. Unit will operate at reduced efficiency below 40 degrees F.
7. Heater is for use outdoors (outside any enclosure).
8. There is adequate fresh air ventilation.
9. Heater is away from gasoline or other flammable liquids or vapors.
10. Heater is away from windows, air intake openings, sprinklers and other water sources.
11. Heater is at least 36 in./91.5cm on top and at least 24 in./31cm. on sides from combustible materials.
12. Heater is on a hard and level surface.
13. There are no signs of spider or insect nests in heater orifices.
14. All burner passages are clear.
15. All air circulation passages are clear.
16. Children and adults should be alerted to the hazards of high surface temperatures and should stay away to avoid burns or clothing ignition.
17. Young children should be carefully supervised when they are in the area of the heater.
18. Clothing or other protective material should not be hung from the heater, or placed on or near the heater.
19. Any guard or other protective device removed for servicing the heater must be replaced prior to operating the heater.
20. Installation and repair should be done by a qualified service person. The heater should be inspected before each use and at least annually by a qualified service person.
21. More frequent cleaning may be required as necessary. It is imperative that control compartment burner and circulating air passageways of the heater be kept clear.

7 Post-Operation

1. Gas control knob is in OFF position.
2. Gas tank valve is OFF.
3. Disconnect gas line.
4. Heater is in upright secure location.

WARNING: FOR YOUR SAFETY



- Do not touch or move the heater for at 45 minutes after use
- Reflector is hot to the touch
- Allow reflector to cool before moving.

Maintenance, Care & Cleaning

To enjoy years of outstanding performance from your heater, make sure you perform the following maintenance activities on a regular basis:

Keep exterior surfaces clean.

1. Use soapy water for cleaning. Never use flammable or corrosive cleaning agents.
2. While cleaning your unit, be sure to keep the area around the burner and control compartment dry at all times. Do not submerge the control valve assembly. If the gas control is submerged in water, do NOT use it. It must be replaced.
3. Air flow must be unobstructed. Keep controls, burner, and circulating air passageways clean. Signs of possible blockage include:
 - Gas odor with extreme yellow tipping of flame.
 - Heater does NOT reach the desired temperature.
 - Heater glow is excessively uneven.
 - Heater makes popping noise.
 - Spiders and insects can nest in burner or orifices. This dangerous condition can damage heater and render it unsafe for use. Clean burner holes by using a heavy-duty pipe cleaner. Compressed air may help clear away smaller particles.
 - Carbon deposits may create a fire hazard. Clean dome and burner screen with warm soapy water if any carbon deposits develop.



In a salt-air environment (such as near an ocean), corrosion occurs more quickly than normal. Frequently check for corroded areas and repair them promptly.

STORAGE:

Between uses:

- Turn the control knob OFF.
- Disconnect the LP source.
- Store the heater upright in an area sheltered from direct contact with inclement weather (such as rain, sleet, hail, snow, dust and debris).
- If desired, cover the heater to protect the exterior surfaces and to help prevent build-up in air passages. Wait until the heater is cool before covering.
- Never leave the LP cylinder exposed to direct sunlight or excessive heat.

SERVICE:

Only a qualified service person should repair gas passages and associated components.



CAUTION: Always allow heater to cool before attempting service.

Troubleshooting

PROBLEM	POSSIBLE CAUSE	CORRECTIVE ACTION
Main burner does not light.	Pilot light will not light when pressing in igniter.	Replace battery in igniter.
	Gas valve may be off.	Turn the gas valve ON.
	Fuel tank may be empty.	Refill the LPG tank.
	Orifice blocked.	Clean or replace the orifice.
	Air in supply system.	Purge air from the lines. Open gas lines and depress the control knob for 2-3 minutes.
	Loose connection.	Check all fittings.
	Gas pressure low with valve open full.	Replace the cylinder or regulator.
	New cylinder or first ignition.	Purge air from the lines.
	Cylinder valve on, no gas flow.	Replace the hose/regulator assembly.
Low burner flame.	Pressure is low.	Replace the LPG tank.
	Tank is low on fuel.	Fill the LPG tank.
	Gas hose is kinked.	Check & straighten or replace.
	Control knob at max.	Check for obstructions at passageways and orifices.
Reflector and emitter screen appear black.	Carbon on the reflector and the emitter screen.	Clean components as needed.
Thick black smoke.	Blockage in the burner assembly.	Thoroughly clean the burner.

Review & Warranty Extension



Extend Your Warranty By Leaving A Review

We want your opinion about your purchase...and we want you to tell everyone about it! Just leave a review for the product on the retailers website where you made your purchase, or at www.jrhome.com, and fill in the online warranty at <https://www.jrhome.com/warranty-registration> to receive a complimentary extra year of warranty protection.

Follow us on:



www.jrhome.com #jrhome #paramount

Warranty

For questions, concerns or problems with our product please email our customer service department:

customercare@jrhome.com

DATED PROOF OF PURCHASE REQUIRED FOR WARRANTY SERVICE

WARRANTY

This product is inspected, tested and carefully packaged to minimize the chance of damage during shipment. If a part (excluding light bulbs, glass and fuses*) within one year from the date of purchase proves to be defective in material or fabrication under normal use, the part will be repaired or replaced. The Company's obligation under the warranty is to replace or repair defective parts at our discretion. Any expenses or damage resulting from the installation, removal or transportation of the product will be the responsibility of the owner and are not covered by this warranty. The owner assumes all other risks arising from the use or misuse of the product. The warranty will be void if the product damage or failure is deemed by the Company to be caused by accident, alteration, misuse, abuse, incorrect installation or removal, or connection to an incorrect power source by the owner. The Company neither assumes, nor authorizes any person or entity to assume for it any obligation or liability associated with its products. Light bulbs and fuses are not covered under this warranty. If you have any questions regarding the warranty or service, please contact us at **customercare@jrhome.com**.

Customer Service :

JR Home Products

Unit 306 - 19100 Airport Way, Pitt Meadows, BC V3Y 0E2

Toll Free : 1-800-561-5550

E-mail : **customercare@jrhome.com**

You MUST register your product within 30 days of purchase to receive warranty service.

Registration can be completed online at www.jrhome.com or by mailing this form.

Si vous éprouvez des difficultés ou si vous avez des questions ou des préoccupations, prière de faire parvenir un courriel à notre service à la clientèle

customercare@jrhome.com

UNE PREUVE D'ACHAT DATÉE EST REQUISE POUR SE PRÉVALOIR DE LA GARANTIE.

AVERTISSEMENT

Ce produit a été soigneusement inspecté, testé et emballé afin de minimiser les risques de dommages durant le transport. Si l'une des pièces (à l'exception des verres, des ampoules électriques et des fusibles*) s'avère défectueuse au niveau de sa fabrication ou de ses matériaux dans l'année qui suit la date de l'achat suite à une utilisation normale, la pièce sera réparée ou remplacée. La compagnie est tenue de réparer ou remplacer les pièces défectueuses à sa discrétion, en vertu de la garantie. Tous frais ou dommage résultant de l'installation, du démantèlement ou du transport du produit demeurent la responsabilité du client et n'est pas couvert par cette garantie. Le client assume tout autre risque résultant de l'utilisation correcte ou fautive du produit. La garantie devient nulle si la compagnie détermine que le dommage ou le mauvais fonctionnement est causé par un accident, une modification, une mauvaise utilisation, un abus, une mauvaise installation ou un mauvais démantèlement ou un branchement à une source électrique inadéquate de la part du client. La compagnie n'est pas responsable et n'autorise quiconque, personne ou entité légale, à accepter de responsabilité ou obligation en son nom, en rapport avec ses produits. * Les ampoules électriques et les fusibles ne sont pas couverts par cette garantie. Pour toute question au sujet de la garantie ou du service, contacter le service à la clientèle à : **customercare@jrhome.com**.

Service à la clientèle:

JR Home Products

Unit 306 - 19100 Airport Way, Pitt Meadows BC V3Y 0E2 Numéro

sans frais: 1-800-561-5550

Courriel: **customercare@jrhome.com**

Vous DEVEZ enregistrer votre produit dans les 30 jours suivant l'achat pour bénéficier du service de garantie.

L'enregistrement sera complet une fois que vous aurez posté ce formulaire ou que vous serez inscrit en ligne.



Warranty Registration Information Form / Formulaire d'enregistrement de la garantie

Name / Nom : _____

Street / Adresse : _____

City / Ville : _____

Province / Province : _____

Postal Code / Code postal : _____

Daytime Phone # / No téléphone jour : _____

Evening Phone # / No téléphone soir : _____

E-Mail Address / Courriel : _____

Product/Produit : _____

Place of Purchase / Lieu de l'achat : _____

Date of Purchase / Date de l'achat : _____

Model # / No de modèle : _____

Serial # / Numéro de série : _____

You MUST register your product to receive warranty service.

For warranty service, contact J&R Home Products at the address, phone numbers listed below within 30 days of purchase. Be sure to have your sales receipt and original date of purchase. All warranty service will be coordinated by J&R Home Products service center.

Vous DEVEZ enregistrer votre produit pour vous prévaloir de la garantie.

Afin de faire valoir la garantie, communiquez avec J&R Home Products à l'adresse et aux numéros indiqués ci-dessous dans les 30 jours suivant la date d'achat. Ayez en main votre reçu et la date d'achat. Toutes les demandes liées aux garanties seront traitées par le centre de service de J&R Home Products.

Please mail to / Veuillez poster le tout à : Parts & Service Department, J&R Home Products Ltd. Unit 306 - 19100 Airport Way, Pitt Meadows, BC V3Y 0E2

120920

Paramount

Questions, problems, missing parts? Before returning to the store, please contact customer service at customer care@jrhome.com or call 1-800-561-5550 7 a.m. - 4 p.m., PST, Monday – Friday

JRHOME.COM

Retain this manual for future use.